

*Knut Grimsrud  
8505 SW 184th Loop  
Aloha, OR 97007*

*Home (503) 649-8053  
Work (503) 264-8419*

## DeLorean Owners Association Regional Chapter 41

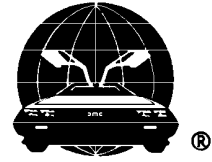

May 27, 1996

### Happenings

by Knut Grimsrud

The cruise up the Gorge for Sunday brunch scheduled for May 5 was canceled due to lack of interest. This was just one of a long series of events that Chapter 41 has put on that has received no attendance. Hopefully the upcoming tech session and BBQ will work out a little better for everyone.

As I am planning on taking my car on a road trip for my upcoming honeymoon, I have a long list of minor fixes to apply to my car -- some of which I hope to complete at the upcoming tech session. Some of the fixes include:

- Adjusting parking brake
- Replacing fuel pump boot and cover
- Replacing transmission backup switch
- Replacing bulbs behind A/C panel
- Installing a luggage rack

With the help of our tech director, I will get the items most interesting to you done on the spot and you may want to come prepared to perform some needed fixes of your own. If you have

problems with your car, this is an excellent forum in which to exchange ideas and advice.



On display at the St. Patrick's Day Festival. I was cleaning hand prints off my fender all day.

### Message From Your Coordinator

Chapter 41 seems in peril of withering due to lack of interest. We are in need of a new events coordinator that can arrange for some revitalizing chapter events that appeal to our members. If you would like to try your hand at "events coordinator for a month" give me a call with your ideas. Also, if we are not meeting your needs, please provide some feedback on how we might better serve you.

## Tech Notes

by Knut Grimsrud

Since my last newsletter, I have had a couple minor problems with my car. These problems were nothing that couldn't readily be handled provided that I knew how to deal with them. My car is also ready for its 100,000 mile tune-up (the odometer only says 97,500, but it is a little low due to some miles put on it with a broken speedo cable and I want to get it all fixed up before an upcoming road trip). In my next issue I (or maybe the technical director) will cover the findings from that overhaul.

### Electrical Issues & Cooling System Bleeding Perfected

I stopped at the gas station on my way home today and was a bit dismayed when my car wouldn't start afterwards (a rather embarrassing situation). My battery has been getting a little weak lately and the voltage finally dropped too low for the starter solenoid to engage properly. When encountering poor cranking performance in your DMC, the battery is not always the cause -- often it is a poor connection to the battery, especially the ground connection.

The battery ground cable attaches to the frame at the trailing arm bolt mount on the passenger side. I had just a week ago cleaned this contact thinking this was the source of my persistent problems. In order to clean this connection, the grounding bolt should be removed and the bolt, washers, and surrounding frame cleaned up with sandpaper or a wire brush. I used the wire wheel attachment to my Dremel to clean the area well. This ensures a proper connection of the terminal to the frame (ground) of your car.

Alas, the problem persisted and my diagnosis was a tired battery. When removing my battery, I was a little surprised that my tie down strap had disintegrated -- there was not much left other than the buckle. Based on the mess I have been cleaning up, I would discourage the use of anything but a sealed type maintenance free battery. The fumes and slight leakage from my battery made a real mess of my battery compartment which was totally unnecessary. I am happy to inform you that my car cranks very

well again, thanks to my new 1000 CCA (cold cranking amps) battery.

I encountered another problem since my last newsletter that most DeLorean owners will encounter on occasion -- a vapor locked water pump. The symptoms are quite easy to recognize, but the diagnosis is often a little trickier. The symptom is simply that your car overheats.

Overheating may result from a number of causes -- in my last newsletter I discussed the thermal switch as one such cause. Other causes include a bad thermostat on the water pump, cooling fan failure (especially if you are still running the original cooling fan relay) and a bad water pump altogether.

I have talked about the cooling system in length in previous articles, so I will not bore you with more discussion on the topic. In my case I had neglected to check the level in the coolant reservoir over an extended period of time and the level had dropped low enough for the system to slurp up air from the tank. The procedure for handling this problem is conceptually simple, but the execution requires a little discussion.

When bleeding the cooling system, overfill the coolant reservoir. The additional volume will be needed when the air is let out of the system and you don't want to have to add more fluid when you are halfway done. You will need about 6 feet of clear flexible tubing that you can attach to the nipple on the water pump on the one end and drop into a bucket in the other. A 10mm box wrench completes the tools necessary for the

procedure (I carry such a “kit” in my car in case of emergencies). I prefer using a clear piece of hose as it allows me to see the fluid and bubbles coming out of the bleeding nipple.

Turn your car on and allow the temperature and pressure to rise in your cooling system. Watch your temperature gauge closely in order to avoid overheating your car. When the temperature is above the thermostat temperature (about the 160 degree mark on your temperature gauge) slowly loosen the nipple with the wrench. Be careful to avoid scalding yourself on the hot coolant. Bleed the system until the pressure is lost or until there are few bubbles coming out through the hose. It is normal to lose some coolant into the bucket in the process.

Close the nipple and wait a little while before you repeat the process. If your car gets too hot, turn it off and continue after it has cooled for a while. I found that I could get a lot of air out of the system after I turned the car off (provided I left sufficient pressure in the system) as the bubbles tend to collect better in the pump housing near the nipple when it is not circulating. I would warm the car up and then turn it off before bleeding the system. After losing pressure I would start the car and run it a little while before turning it off to repeat the procedure.

When you can no longer get air from the nipple, you are done. Be careful not to bleed so much fluid from your system during the process that your reservoir gets low. If it gets too low you will slurp up more air and you will be back at square one. When you are finished, recheck the level in the reservoir and fill it as necessary. The tank should not be completely full as it is used to handle expansion as well. When checking the fluid level (I use the all metal tank that I can not see the level in without removing the cap) be aware that releasing the pressure at the bottle will aggravate any vapor lock condition you may have.

When your cooling system has air pockets trapped in it, removing the coolant reservoir cap introduces additional air to the system. The gas

trapped in the cooling system expands pushing fluid back up into the reservoir. This can give the false impression that there is plenty of fluid in the system. A good clue that this is happening is to listen for gurgling sounds when you release the pressure by taking the cap off. Also, if your car is overheating and the coolant overflows when you take the cap off, you likely have large pockets of air trapped in the system.

In emergency situations, the bleeding procedure can be carried out without the use of the requisite tubing, although some sort of wrench is required to loosen the bleeding nipple. Provided that your nipple is not frozen (you might try loosening it with a 10mm wrench sometime and convince yourself it is not frozen) it can be loosened with an adjustable wrench or even a pair of pliers. Note that the toolkit that came with your car includes a 10mm wrench. Be aware that you will inevitably spill coolant on your belts in the engine compartment and that the alternator belt may slip a little bit afterwards until the fluid dries up.

Do not open the bleeding nipple when there is no pressure in the cooling system. Doing so can let air into the system rather than letting it get pushed out.



### **Contributing Articles**

You might notice that this issue has no contributing articles. Occasionally I will solicit articles from qualified people I know, but unsolicited contributions would be most welcome. Contributing to the Chapter 41 newsletter does not require that you be an expert in any particular field, just that you enjoy the DMC and have some interesting experiences to share with other chapter members.

Contributions should be sent directly to me. Should you have some photos to accompany your article, I will be glad to return them after inclusion in the article.

## Manual Fan Override Project

In this final issue on the manual fan override project (which has become a generalized control system), I will cover the digital portion of the circuit and the issues related to manufacturing a circuit of sufficient quality to put in your prized car.

The digital portion of the system is the simplest part (in my opinion) and consists of a single part -- a programmable GAL (generic array logic) device. Programmable devices brings to mind such complex devices as microprocessors and microcontrollers. In our case, we are using a much simpler device that consists of a number of inputs and a number of outputs that can selectively be connected together. It is not feasible for me to explain the technology behind programmable logic devices nor the expertise required to program these devices. Instead, I will offer to provide programmed parts (which retain the programming even when the power is off) for the cost of the part to anyone in the club who wants one. Alternatively, if someone provides me the part I will burn the program into them free of charge.

The figure illustrates the part used in this circuit -- a GAL 20V8B available from a number of sources. The price for the part ranges from about \$2 to \$4 depending on the speed of the device. In our case, we are clocking the device very slowly (these devices can support clocking speeds in excess of 100MHz and we are clocking at less than 100Hz, a million times slower than the device is capable of). In the configuration we program the device in, it has 12 inputs, 8 outputs, a clocking input, and an enable input. Of these inputs and outputs we only use a couple -- the part is capable of performing more complex functions than we program it for. The device also needs stable 5V power.

The clocking input is driven by the clocking circuit discussed a couple issues ago, and the enable input is connected directly to ground

(which enables the outputs). The input and output pins are connected to your car's systems via the interface circuitry covered in the last issue. We will use two outputs and three or four inputs. The chip is powered by the 5V regulator discussed several issues back.

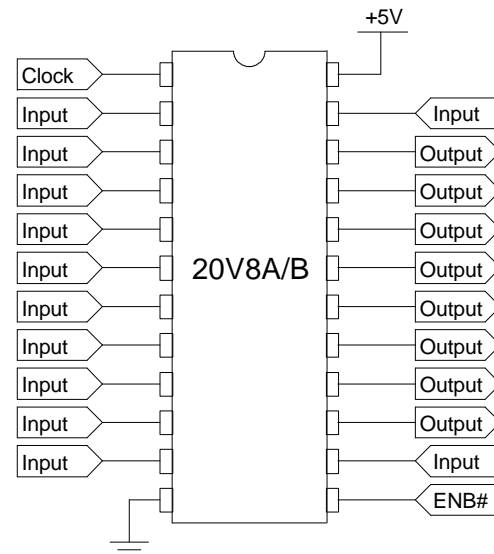

As I mentioned before, programming the chip is beyond the scope of this newsletter. The final piece to the circuit project is putting it all together. For the circuit to be suitable for use in my DeLorean I required that it not only be very robust, but also that it looked professional. To meet these goals, I fabricated printed circuit boards for mounting the components to and housed the finished board in a small black plastic enclosure similar to those used already in the relay compartment for the impulse unit and other modules. The finished unit was interfaced to the car's wiring harness using the same style connectors already used in the compartment and the end result looks good. I invite you to inspect the completed project at the upcoming tech session.

The following figure represents the printed circuit board (PCB) artwork used in the manufacture of the project. The design was done so as to allow it to be manufactured on a single-sided board of which I have a couple spares if you are interested in attempting to assemble a circuit of your own.

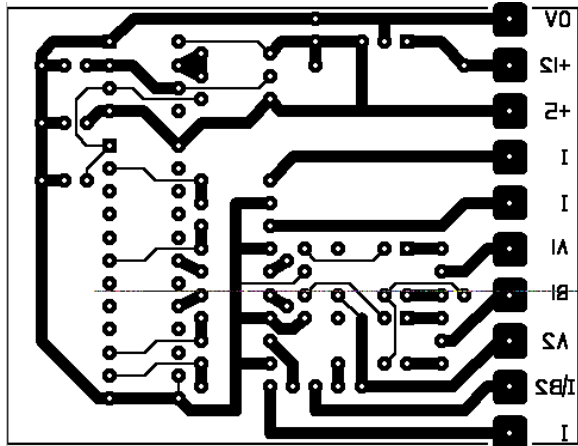

The lettering on the circuitboard artwork appears backwards because it represents a top view of the etching pattern on the back side of a board. The board measures 2.5 x 2.0 inches and the component placement is depicted in the next figure. The 20 pin GAL should be mounted with a socket so that it can be programmed, and all the other components can be soldered directly to the board. A couple jumpers are included on the board to allow the board to be configured for different applications.

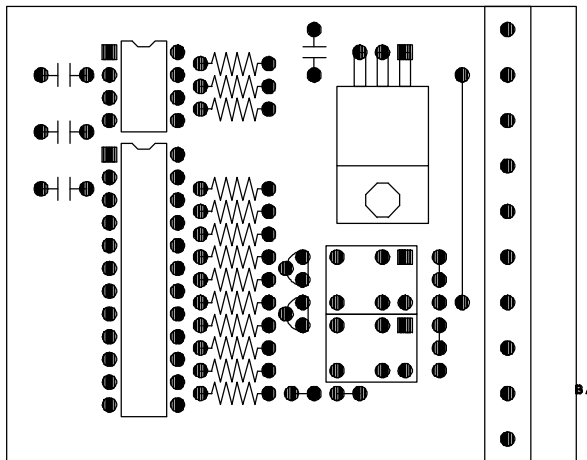

If you are experienced with electrical circuits, you should be able to pick out the various projects from previous newsletters in the circuitboard. The 555 timer circuit is in the upper left corner of the circuit, the voltage regulator is in the upper right, the digital GAL is in the lower left, and the transistors and relays used to drive the automotive systems are in the lower right.

The resistors in the center interface input signals to the GAL as well as other misc functions.

The parts used in completing the circuit have been discussed in various previous newsletters, but if you would like a more detailed list, feel free to contact me. Also, if you would like the GAL program used for the fan override function, contact me.



### Project Info

The car controller project is quite versatile and can perform most functions requiring up to 4 inputs and 2 outputs. If you have an interesting application of a controller for your DMC or have problems you would like considered, contact me with your ideas. If I like your idea for a controller application I will build you a controller for that application based on the versatile circuit already designed and include information on it in upcoming newsletters.

Be advised that the controller outlined in this newsletter over the last several issues should not be used in safety critical systems of your car. Also, the design comes with no guarantees of any sort. Although you are free to use the information presented in this series of articles for your own use, I consider the design my own and it should not be pursued commercially.

Should you be interested in building the project, feel free to contact me regarding programming for your GAL part as well as availability of etched circuit boards. I will provide both at cost to Chapter 41 members as time permits.



Halloween at my place. My jack-o-lantern was a masterpiece!

## For Sale & Wanted

---

*Advertisement of DeLorean related items is provided as a service to Chapter 41 members free of charge.*

---

*Wanted: Interesting application of the car controller project. Will trade for completed controller.*

*Contact Knut for info.*

---

## Chapter 41 Events Calendar

### ***Tech Session & BBQ***

Date: Sat. June 15  
8505 SW 184th Loop, Aloha (Knut's house -- map attached)  
Bring your own meat to BBQ and something else to share with everyone.

Agenda: 11:00 - Fix everything that needs fixing (and some that don't)  
12:00 - Charcoal lit, enjoy a BBQ when it's ready

Because of poor turnout, I will be holding the next event at my house rather than making arrangements for other facilities. We can not hold the event at the usual poolside location since I no longer rent an apartment at those facilities. For those highly engaged with their repairs, some tinkering will likely be concurrent with lunch.

### ***Upcoming events (to be finalized)***

Unknown Date All British Field Meet. This event is usually held around Labor Day weekend at Portland International Raceway

Sept. 14th or 15th Join the Pacific Northwest DeLorean Club for Malibu Car Racing in Beaverton.

