

Knut Grimsrud
8505 SW 184th Loop
Aloha, OR 97007

Home (503) 649-8053
Work (503) 264-8419

DeLorean Owners Association Regional Chapter 41



October 28, 1996

Happenings

by Knut Grimsrud

Knut's car takes *First Place People's Choice Award* in his class at the All British Field Meet three years running! Had you been there, competition would have been a little harder, but with the only car in my class I easily walked away with the first place trophy (they wouldn't give me second and third as well).

The All British Field Meet is an annual event held at Portland International Raceway around Labor Day weekend each year and caters to British cars of all makes and years. Attendance is usually good and about 400 cars were on exhibit this year. Conditions were ideal this year with mild temperatures and sunny skies.

Although there is sometimes debate over whether the DeLorean is a legitimate "British" car, DeLoreans are welcome to the show and they always draw a crowd from other auto enthusiasts and aficionados.

As part of the field meet, entrants are invited to

participate in the slalom race. I had a great time with this last year, but this year I had to decline due to engine problems I was experiencing (more on that later). I encourage members to participate in similar shows in the future as they are generally very enjoyable.

NorthWest Car Collector's Expo

Also since my last newsletter, the Collector's Car Expo was held at the Multnomah expo center. Although similar in concept to the All British Field Meet, the quality of cars displayed at the

Continued....

Message From Your Coordinator

The joint event I had planned with the Pacific Northwest DeLorean Club for a day of Malibu Grand Prix racing was canceled at the last minute due to poor weather conditions. The PNDC is a very active club in the Washington area and on occasion we have the pleasure of socializing with them at various joint events. Incidentally, Malibu Grand Prix racing was originally a venture started by John Z. DeLorean.



DeLorean in a haystack. The All British Field Meet had about 400 entrants this year.

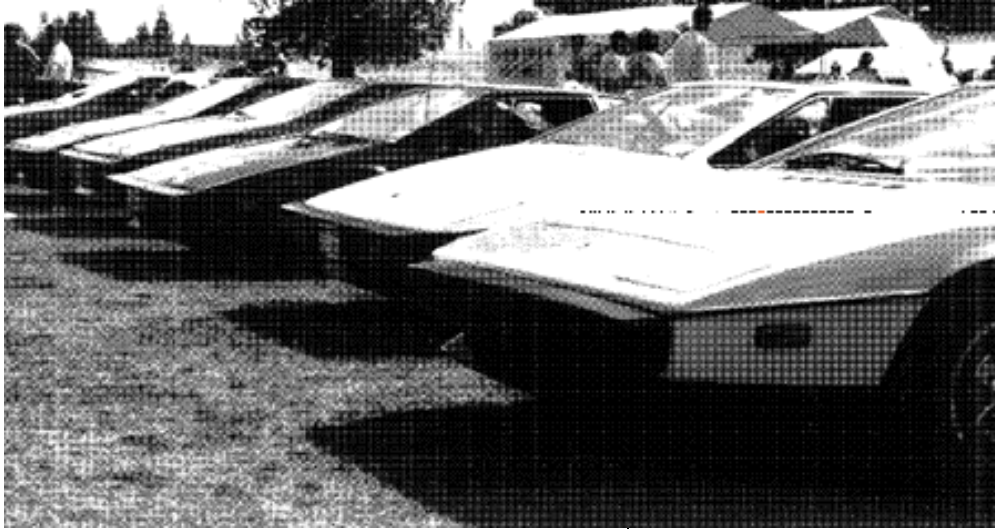

Loti on display at the ABFM. I have always had an affection for them.

expo far exceeds that of the ABFM. Cars are displayed by invitation only and there is no fee to participate.

With a few last-minute calls to the event program chair, I got my ragged DeLorean on display where it drew a lot of attention despite the high-quality (high value) collectibles on display. In chatting with other collector car owners, we came to the conclusion that I got by far the most attention per dollar spent.

Regional DeLorean Promotional

In unrelated regional news, Thorn Apple Valley brand just wrapped up a regional promotional campaign featuring the DeLorean. As part of their promotion they held a sweepstakes in which they gave away a DeLorean. I met with the regional event coordinators for one of their promotional events where I simply parked my car next to their cookout and display stand for a couple hours. Such exhibits often do much to promote the DeLorean marquee and can be fun excursions in themselves.

Despite my sending in 40+ sweepstakes entries, I did not win the DeLorean (much to my wife's relief).

You can't blame me for trying!

DMC Heart Transplant

After 100,000 miles, my DeLorean engine finally required some major work. Rather than having it re-built, I had the entire engine replaced with a brand new one.

My old engine is now on a stand in my garage where I will re-build it at my leisure. I anticipate that I will swap the engines back after the next 100,000 miles.

After overcoming some initial denial and price shock and resolving a proper course of action, I found the engine replacement to be relatively painless and straightforward. Foreign Car Specialists had the new engine running just 2 days after receiving the replacement motor mounts. I will include more on the DMC heart transplant in the next newsletter.





WIN A LEGENDARY DELOREAN!

SWEEPSTAKES ENTRY FORM

FROM THORN APPLE VALLEY
BUN-SIZE SMOKED SAUSAGE



SWEEPSTAKES

Name _____

Address _____

City _____

State/Zip _____

Mail completed entry form to: Grill Crazy '96 Sweepstakes, P.O. Box 903, Newark, NY 14513-0903. Entries must be received by 9/30/96. No purchase necessary. See back for details.

©1996 Thorn Apple Valley, Inc.



BUN-SIZE SMOKED SAUSAGE

Chapter History

This marks the thirteenth newsletter that I have assembled on behalf of Chapter 41 of the DeLorean Owners Association over the past couple years. In commemoration of the lucky thirteenth issue, I have created a cumulative table of contents.

Issue #12	August 4, 1996		
	Happenings	-	Tech Session & BBQ report. Fuel system contamination avoided.
	Cruising	-	Honeymoon road trip experiences in the DMC w/ luggage rack.
	Tech Notes	-	Front suspension overhaul project (Part 1).
Issue #11	May 27, 1996		
	Happenings	-	The gorge cruise that didn't happen.
	Tech Notes	-	Electrical issues & cooling system bleeding perfected.
		-	Fan/Controller project (Part 4).
Issue #10	April 14, 1996		
	Happenings	-	St. Patrick's Day Festival at Kell's Irish Pub/Restaurant.
	Twin Turbo	-	Contributing article on Turbo-Manifold twin turbo experience.
	Tech Notes	-	Cooling system revisited.
		-	Fan/Controller project (Part 3).
Issue #9	January 14, 1996		
	DeLorean Expo '95	-	Report on the DeLorean Expo in Las Vegas.
	Stainless Steel	-	Contributing article on the properties of stainless steel SS304.
	To Drive or Not	-	Contributing article on the merits of driving your DeLorean.
	Tech Notes	-	Fuel system electronics.
		-	Fan/controller project (Part 2).
Issue #8	October 28, 1995		
	Winery Tour	-	Tour of the region's many wineries.
	All British Field Meet	-	Racing the DeLorean in the slalom race following the exhibit.
	Door Lock Problems	-	Common door lock problems and electrical fixes & clarifications.
	Electrical Modifications	-	A/C mode illumination & fan override basics (Part 1).
Issue #7	July 10, 1995		
	Tech Session & BBQ	-	Testing stainless panel durability with a hammer.
	Crash Performance	-	Postmortem on a rear-end collision in DMC.
	B&B w/ DMC	-	Experiences at a wonderful B&B in Ocean Park, WA.
Issue #6	March 18, 1995		
	Portland Irish Festival	-	On display at Kell's for drinks & entertainment.
	Interior Restorations	-	Recommendations for headliner and seat restoration.
Issue #5	February 11, 1995		
	Camp 18 Brunch	-	Sunday brunch at Camp 18.
	Insurance	-	Review of some insurance alternatives.
	Care & Feeding	-	Tips on keeping the stainless looking good.
Issue #4	December 26, 1994		
	Holiday Dinner	-	Holiday dinner plans at Heathman Hotel.
	DeLorean & the Internet	-	Chapter 41 establishes an internet presence & DMC FAQ.
Issue #3	Not dated		
	Cannon Beach Rally	-	Chapter 41 joins PNDC for rally with 15½ cars.
	Regional Service	-	Experiences and recommendations for regional DMC service.
Issue #2	Not dated		
	Poolside BBQ	-	Eleven cars show up at Chapter 41 inaugural event.
Issue #1	Not dated		
	Organization	-	Invitation to Chapter 41 inaugural event.

Tech Notes

by Knut Grimsrud

In the last issue I started the suspension restoration project by going through some disassembly procedures. In this issue and the next, I will continue with the disassembly procedures, and in following articles I will cover repairs and re-assembly. I completed the project some time back and am very pleased with the results. The front suspension is completely restored and the handling is more precise than ever. I lowered the front of the car $\frac{3}{4}$ " by having the springs cut and re-formed and the result is a very natural look with the nose high attitude tamed. Please note that I am only conveying my experiences with the project and I will in no way be liable for your dropping your DMC on you or having your wheels fall off.

Disassembly Continued

After the procedure outlined in the previous issue, the suspension should appear as in the photo below – the brake caliper and hub (51) are removed and only the snub axle (12) is left protruding from the steering knuckle (1) with the disk shield attached. Note the brake caliper suspended with a rope – do not let it hang from the hydraulic line. All the photos are of the right (passenger) front suspension assembly (the exploded-view diagram is of the **left** side).



The remaining disassembly should only be carried out if you have replacement ball-joints on hand. Separating the knuckle from the various ball-joints usually damages the ball-joints (or at the least thrashes the ball-joint boots).

Do **not** remove the shock absorber (35) before separating the ball joints (13, 15, 47) since the shock will solely support the lower suspension arm (31) once the knuckle (1) is removed (if the shock is severely damaged such that it may not support the lower suspension arm against the force of the spring (42), the lower suspension arm (31) must either be supported or a new shock put in place first).

Separating the ball-joint studs from the knuckle requires a little more effort than the workshop manual makes it sound. You will require a "pickle fork" for the procedure. I got good results using a fork with $\frac{3}{4}$ " gap between the prongs. You can rent a pickle fork from many tool shops including NAPA. Start with the tie-rod end (13) first since it is a little easier than the upper (47) and lower (15) ball joints and because it is easy to get to. Loosen and remove the nut (13) securing the tie rod stud to the steering knuckle (1). I found that some of the ball joint nuts seemed to be standard sized, rather than metric. Since these nuts are very tight, take care to avoid selecting a wrench that is not snug on the nut. Since I had no standard sized tools, I found myself using a close metric that was so snug that I had to tap it onto the nuts for the upper and lower ball joints.

Using the pickle fork, position the tool such that the tie rod stud is between the prongs and the prongs wedge between the tie rod end and the steering knuckle. Using impact (a hammer), drive the pickle fork between the two members thereby wedging them apart. On my car it took considerable force to separate the two. Take care to drive the fork backward toward the snub axle so that the impact compresses the knuckle arm that the tie rod attaches to thereby minimizing the risk that you break it off. Also take care to avoid striking your stainless body panel.

Repeat the procedure for the upper and lower ball joints (47 and 15). The nuts on these are quite tight and you might try soaking them in a penetrating oil overnight before starting the procedure. Again, these nuts did not seem to be metric and you should take care to use a wrench that is snug enough to avoid rounding the nuts. At this point, the setup should look as in the photo below.

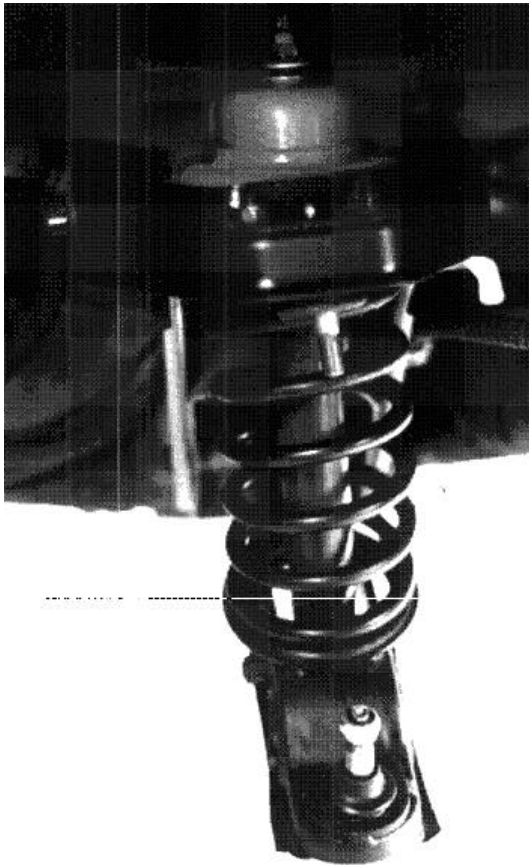

The brake caliper can now be positioned out of the way better by suspending it near the front of the car. The hydraulic line previously passed between the coil spring and the knuckle preventing it from being positioned anywhere but near its mounting point. The tie rod can simply be positioned out of the way.

Remove the upper wishbone control arm (53) by removing the 19mm nut and withdrawing the long bolt (43). Almost all the larger suspension bolts are 19mm, so the torque wrench you use for removing the wheels will come in handy. Keep track of where all the spacer washers (44 & 45) go for re-assembly. You should be left with just a coil spring, shock absorber and lower control arm as in the photo below.



The tie rod end is easily removed from the tie rod by loosening the lock nut (14) and unscrewing the tie rod end. Although you might take care to count the number of turns it takes to remove the tie rod end, in practice you will need a front end alignment in any case after the procedure. You just want the front end straight enough to drive to the alignment shop afterwards.

Removing the upper ball joint (47) from the wishbone takes a little more work. The upper ball

joint is not fastened with bolts and nuts (48, 50) as indicated in the diagrams, but with some strange fasteners that cannot be removed without destroying them. New replacement ball joints are to be fastened with nuts and bolts. Instead of nuts on the end of the fasteners, there seem to be some sort of sleeves crimped to the end of the bolts. The service manual says to crack these sleeves with a nut cracker, but due to their awkward position as well as their round shape, I was

unable to get a nut cracker to adequately split the cheap nut substitutes.

I instead used my Dremel cutting tool to simply cut the "nipple" ends off the four mounting bolts and easily removed the upper ball joint from the wishbone.

In the next issue I will finish the destruction of the front suspension.

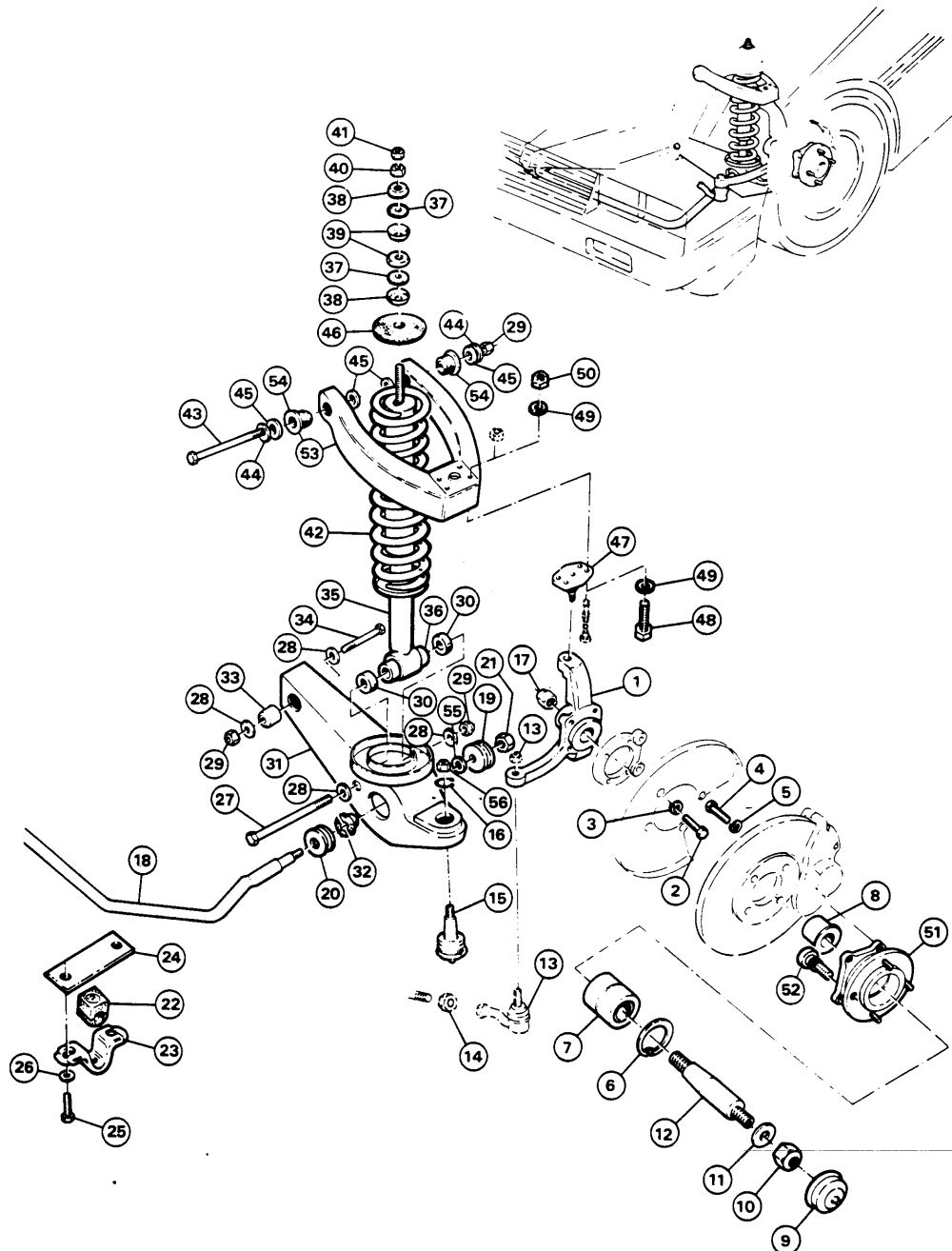

Chapter 41 Events Calendar

'97 Kickoff Meeting & Dinner

Date: Sat. Jan. 18, '97 6:00pm
Stuart Anderson's Cattle Company
3800 SW Cedar Hills Blvd.
Beaverton

Please RSVP to Knut beforehand so that appropriate accommodations can be made.

Upcoming events (to be finalized)

Our club is in need of an events coordinator to help plan future events. If you are interested or have a suggestion for an event, please call me.

Chapter 41 releases new DeLorean FAQ

The popular internet DMC FAQ (Frequently Asked Questions) has been sponsored by Chapter 41 and has just received a much needed update. Expect it to appear at your favorite DeLorean related WEB sites over the next few weeks. If you would like to contribute to the information in the FAQ, please contact me.

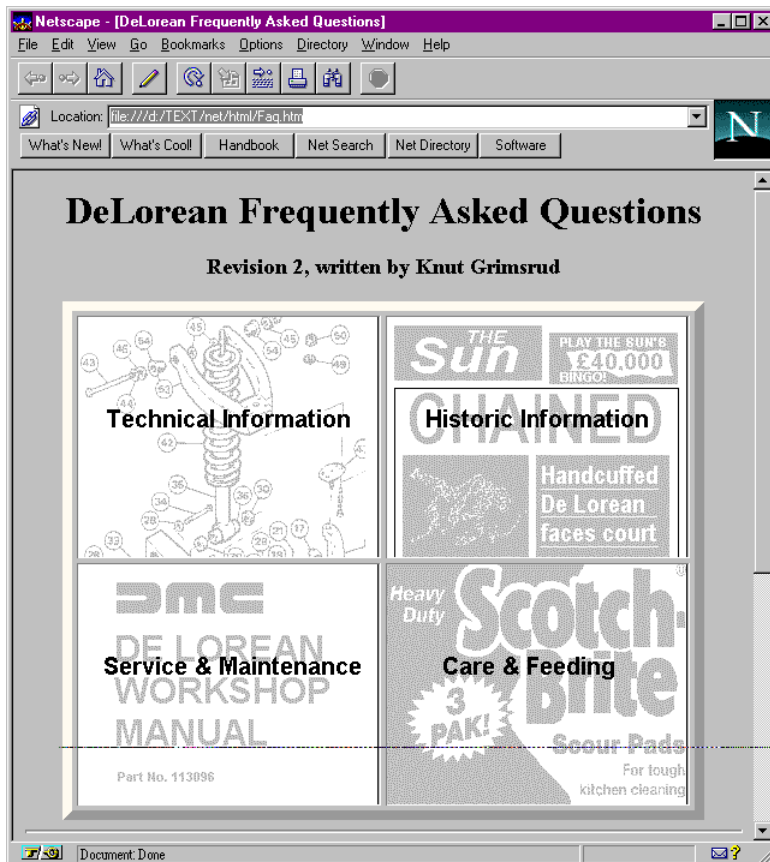

For Sale & Wanted

Advertisement of DeLorean related items is provided as a service to Chapter 41 members free of charge.

*Wanted: Performance components for PRV6 ground-up rebuild
Oversized sleeves & forged pistons?*

*Contact Knut H:649-8053
W:264-8419*

Wanted: DeLorean with damaged or missing engine for restoration project.

*Contact Knut H:649-8053
W:264-8419*
