

*Knut Grimsrud  
8505 SW 184th Loop  
Aloha, OR 97007*

*Home (503) 649-8053  
Work (503) 264-8419*

## DeLorean Owners Association Regional Chapter 41

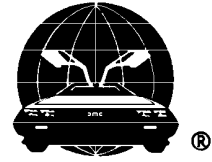

December 27, 1996

### **Happenings**

by Knut Grimsrud

Since there were no scheduled events since my last newsletter, I have little to report on regional events. I did participate in the PNDC (Pacific Northwest DeLorean Club) Christmas party and gift exchange where we enjoyed the company of about 25 PNDC members.

This year's Christmas party was held at the McDonough's home in Olympia. Despite poor weather conditions, we made pretty good time and were rewarded with a full dinner, gift exchange, and camaraderie. I made off with a bottle of wine and a stainless steel coffee mug – much envied by the other guests. I look forward to meeting up with the PNDC for future events.

At the party I obtained a DMC patch that I expertly sewed to my black Eddie Bauer jacket. Since then, I have been asked by several people whether I currently work for DMC. The spectrum of people approaching be about this ranges from gas station attendants to physicians. My wife and I have received plenty entertainment value from this little patch.



DeLorean in the rough

### **Message From Your Coordinator**

As you have likely noticed, I have recently obtained enhanced scanning and printing capabilities. As I learn how to make use of the new capabilities, I hope to increase your enjoyment with the newsletters. I doubt that the operating costs will be any different, and as usual I absorb the cost of producing the newsletters (aside from postage).

The equipment will also be used for a document archiving project in cooperation with a representative of a large dealership in Texas that was involved with the DeLorean project from the beginning (see article later in this issue). A large number of historic documents are being digitized and archived.



## DMC Documentation Project

I have just started a project in cooperation with a representative of a large dealership in Texas that was heavily involved with the DeLorean project from the start. The project entails digitizing and cataloging a wealth of original DMC related documents including internal memos dating back to the inception of DMC and continuing through the entire DMC era.

Excerpts of this data will appear on my WEB page as time permits, and after a large body of data has been cataloged I may see about an alternate document retrieval mechanism – possibly having some CD-ROMs made with the document library.

Below is an excerpt of an early memo from John Z. DeLorean to his investors reporting on the

progress of the development effort. The materials that I will be cataloging includes such memos as well as internal DMC memos. Also much of the early promotional materials, stock certificates, dealership application forms, audit reports from Arthur Anderson, company prospectus, etc. So far I have been amazed at the wealth of documentation I have been receiving and admit to quickly becoming engrossed. As I clear the backlog and get a clearer picture of the scope of the materials, I will be in a better position to determine the proper way of disseminating the information.

If you have a particular interest in the materials or in this project, feel free to contact me.



DE LOREAN MOTOR COMPANY  
P.O. Box 427 Bloomfield Hills, Michigan 48013  
313/645-2215  
July 22, 1976

Mr. Robert J. Marco  
530 West Forest Drive  
Houston, TX 77024

Dear Mr. Marco,

As we move closer to our objective of building a new car, it seems most appropriate to take a few moments to advise you of our progress and current activities. Increasing activity permitting, I hope to correspond with you on a more regular basis.

### Prototype Development

Under present supplier commitment schedules our first prototype will be completed in September. As you know, our original build schedule was re-scheduled as a result of the delays caused by news articles last January. Those articles might, according to our legal counsel, later have been construed as promotional by the SEC. Rather than risk any possible taint on the activities or our company, we elected to cease all activities, afford each investor the opportunity to recind his investment decision, and then begin anew. We have taken advantage of this delay to incorporate a number of product improvements into our car.

At this point, the massive molds for the one piece underbody have been completed and over 50 percent of the stainless steel stampings for the prototype car have been received. We are very pleased with their quality.

### Corporate Development

Parallel with our product development, we have also taken several other significant steps within our corporate structure. Recently we were able to obtain the services of Roger Ramsey, formerly Vice President - Finance of Browning-Ferris Industries (NYSE) as our financial officer and Mr. Tom J. Fajó, founder of that company as chairman of our Executive Committee. Their background provides us with proven experience in building a major company. Through their efforts we are progressing on a deliberate program of overall corporate development, and growth strategies.

### Dealer Program

Enclosed is a copy of the scheduling chart for the creation of our dealer body. As you will note, we plan to have

all dealers in place by December 31. This will be done pursuant to a registration statement to be filed with the Securities & Exchange Commission.

Early in June Mr. C. R. (Dick) Brown officially joined our company as Vice President. Dick was formerly general manager of Mazda of America and was personally responsible for building their national dealer organization. Dick has assumed full responsibility for the creation of our dealer organization. He brings a great deal of valuable experience and talent to the company and has already made significant progress.

### Engineering

Bill Collins and his team, too, have made significant progress. All aspects of our product development are on schedule. The prototype development, reported earlier, has taken much of Bill's time, as has final engineering specifications. The enthusiasm and dedication to quality of all the designers and engineers is constantly reflected in our product. We continue to hold to the integrity of our initial concept.

As I travel in connection with the development of the company I hope to be able to visit with many of you personally and show you some photographs of our product development and review with you many of our activities, including the results of our first product clinic which is mentioned in the enclosed article from Automotive News.

We continue to move toward our goal of building a very high quality sports car in America. Seldom do you find such experience and enthusiasm in one company. I am most pleased that we have been able to bring both of these fine business traits to DeLorean Motor Company.

Sincerely,

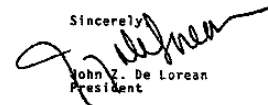

John Z. DeLorean  
President

/lg

encl.

## Tech Notes

by Knut Grimsrud

In the last issue I covered the majority of the procedures for destroying the front suspension of your DeLorean. In this issue I will complete the procedures for dismantling the front suspension and cover items to be replaced or serviced prior to re-assembly. Please note that I am only conveying my experiences and will in no way be liable for your dropping your DMC on yourself or having your wheels fall off.

### Disassembly Continued

After the procedure outlined in the previous issue, the suspension should appear as in the photo below – only the lower control arm and spring remain of the front suspension assemblies (note that the swaybar has also been removed – see errata at right).



Partially disassembled front suspension.

The next step involves compressing the coil spring with a spring compressor in preparation for removing it. Do not remove the shock absorber until the spring is sufficiently compressed to release the tension from the lower control arm. Doing so will allow the spring to

### Errata

In the last issue, the front swaybar had already been removed prior to the described procedure. The front swaybar may be removed at any time, although it is convenient to remove it prior to the procedure described in the last article to get it out of the way. The swaybar is removed by removing the retaining bolts (21) attaching the swaybar to each lower control arm and the bolts (25) securing the clamping brackets (23) to the front crumple tube assembly. The doughnut shaped bushings (20) securing the swaybar to the lower control arms should be replaced as well as the bushings (22) securing the swaybar to the front crumple tubes.

While you are in the vicinity, examine the condition of the front crumple tubes (the front portion of the frame to which the radiator and sway bar are attached). This area was designed to be easily crushed in a front impact and in some cases can be unknowingly damaged. A DMC recall strengthened this area with additional brackets that should be fitted to the crumple extensions.

force the lower arm downward without restraint and will damage the lower control arm mounting area. Also, keep in mind that compressed springs store a lot of energy and are very dangerous. Follow the precautions for the use of your spring compressor. Spring compressors can be rented from most auto parts places such as NAPA.

Mount the spring compressors as per instructions and slowly tighten them so as to compress the spring. Ensure the spring is being compressed evenly and that the compressors are secure during tightening. Having one slip off can inflict damage to both you and your car. You may be

surprised at how much the spring must be compressed before the tension is released from the lower control arm – I nearly ran out of travel on my compressors during removal.

Once the spring is adequately compressed and the compressors are secure, remove the shock absorber. Your front suspension should look as in the figure below.



Compressed spring ready for removal.

Remove the compressed spring (take special care when handling compressed springs) and the rubber seat (46) on which it rests at the top of the suspension tower. If you are having your springs modified, slowly decompress the spring in order to remove the spring compressors.

With the suspension disassembled, restoration work may proceed. Check the condition of the suspension towers and the mounting point for the lower control arm. Corrosion is often concealed underneath the epoxy coating which promotes rust by trapping moisture once it becomes

separated from the underlying metal. All loose epoxy should be scraped away and the underlying metal treated with a rust deactivator before repainting. On my car I found several areas that required treatment – gone unchecked, I have heard of DeLoreans collapsing due to corrosion near the suspension mounting areas.

Now that you have gone to all the trouble, replace all the rubber suspension bushings. The bushing for the lower control arm (33) in particular usually requires replacement. So common is failure of this bushing that they can no longer readily be obtained. The recommended course of action used to be to purchase a rear upper control arm (which comes with two bushings fitted) and press the bushings out of the new arm. This is no longer necessary thanks to DeLorean Motor Center which is now re-manufacturing new bushings. Give them a call for pricing and availability before you have your bushings pressed out. Removing the lower suspension bushings will require the services of a machine shop with a suitable press (the same goes for having your new ones pressed in).

The bushings for the upper wishbone (54) are not as difficult to remove and you can likely remove them yourself if you have a good vice. With the tools available to them, however, a machine shop can remove these bushings in a matter of minutes for a minimal labor fee. Many parts suppliers (such as NAPA) offer machine shop service as do many auto service centers (such as Foreign Car Specialists). I found that the new upper wishbone bushings were not very tight upon refitting them and had them secured with two small spot welds. Care must be taken when applying a small bead to avoid heating the bushing too much as the rubber will melt.

The front swaybar bushings should also be replaced. The swaybar is an integral part of the front suspension and provides all the lateral strength to the suspension geometry. If you have a hard time maintaining a good wheel alignment, you may suspect poor rigidity provided by the swaybar. The doughnut shaped bushings (20) securing the swaybar to each lower control arm

as well as the bushings (22) attaching the swaybar to the crumple tubes should be replaced. Note that the parts diagram is not correct in the area where the swaybar attaches to the lower control arm. There are only two doughnut shaped bushings (identical) in addition to washers/spacers/ hardware.

With the suspension parts (lower and upper control arms and spring coil) out of the car, I took the opportunity to have them restored further by having them thoroughly cleaned, sand-blasted and refinished. I also had the springs modified slightly in order to lower the front of my car by about  $\frac{3}{4}$  inch.

If you are planning on modifying the springs, take a couple factors into consideration. First, a modest change will likely be most successful and avoid any regrets later (as well as unwanted side effects such as wheel rubbing and suspension travel problems). Second, the springs may not merely be cut without also reshaping them. The DeLorean springs are wound tighter near each end in order to sit properly in their seats and to load them evenly. If the spring is merely cut without also being reshaped, the end that is cut will end abruptly and may damage the seat on which it rests. Also, the first coil of the cut end of the spring will take higher stresses than the rest of the spring.

I had good luck with the work done by Charley's Drop Shop in Troutdale (667-2636 ask for Ron). The work was reasonable and I was pleased with both the refinishing of the suspension arms and the cutting and reshaping of the coil springs. I had  $\frac{1}{2}$  coil removed and the cut end reshaped resulting in the front end of my car being lowered about  $\frac{3}{4}$  inch. In my case the bushings were in such bad shape that I suspect replacing them raised the front of my car a bit which was overcome by the cut springs. You might find that cutting  $\frac{1}{2}$  coil and reshaping the springs will lower your car slightly more than the  $\frac{3}{4}$  inch it did on my car.

You might want to keep track of which spring came out of the driver's side and whether your

car had "driver's droop" incurred by prolonged use with no passenger. This can be compensated for when the springs are modified.

The wheel bearings (7), ball joints (upper (47) and lower (15)) as well as tie rod ends (13) are good candidates for replacing, and may require replacement after having been dismantled due to damage inflicted during disassembly. I found that the lower ball joint was difficult to obtain, while the upper balljoint and tie rod ends were readily available. Instead of an original, I used a cross referenced lower ball joint from NAPA that Darryl at Specialty Automotive helped me find. This ball joint is very slightly different from the original – it does not have the retaining ring (16) the original does. Since the pressure on the ball joint is assured by the suspension spring and the geometry of the front suspension, this is not a serious problem and will not affect the performance or safety of the ball joint. I did, however, again find that the fit was not as snug as I would have liked and secured the ball joint with a couple small weld spots. Again care should be taken to avoid overly heating the ball joint as they sometimes have internal nylon components.

When re-assembling the front suspension, I installed the lower control arm (with its brand new bushing and ball joint already in place) and then installed the springs with the cut end up into the rubber seat at the top of the shock towers. I arranged the top rubber seat for best fit with the top of the spring by rotating it until its previous indentation matched with the spring. The entire assembly (spring plus upper rubber seat) was rotated so that the end of the bottom portion of the spring was in about the 9 o'clock position on its lower seat. (the last coil on the bottom of the spring goes around the outer portion of the seat and ends before it goes around the back). Keeping this in mind before you compress the spring with the spring compressors may save you a bit of trouble.

Replace as many of the nuts and bolts as is practical. With the high torque settings for most of the suspension parts, nuts and bolts are easily

damaged – since they are relatively inexpensive and easily obtainable at most hardware stores (I got most of mine at Ace Hardware) this is a small price to pay. When purchasing new hardware be sure they are of the proper quality/grade for suspension use.

Install the shock and be sure the shock is securely in place before removing the tension from the spring as the spring will force the lower arm downward without adequate restraint unless the shock is in place. The rest of the assembly procedure is quite straightforward. I installed the upper wishbone and steering knuckle next. Be sure when installing the steering knuckle that you bring the brake caliper into position first since its hydraulic line is routed between the steering knuckle and the coil spring.

With the new nyloc nuts on the various ball-joint studs, I found that I was not readily able to tighten the nuts, since the ball would rotate (this was especially the case with the tie rod ends). I resolved this problem by first tightening the tie rods with regular nuts in order to freeze the stud in its seat before loosening the nut and re-tightening with the supplied nyloc nuts.

On the original DeLorean suspension, some of the suspension nuts are of the castle type with a cotter pin running through them (in fact, one of the suspension recalls was to add castle nuts with cotter pins due to these nuts loosening and posing a hazard). Take care to torque these nuts properly and ensure they are of the appropriate nyloc type. The supplied nuts with your suspension parts are recommended unless they have no suitable way of locking the nut.

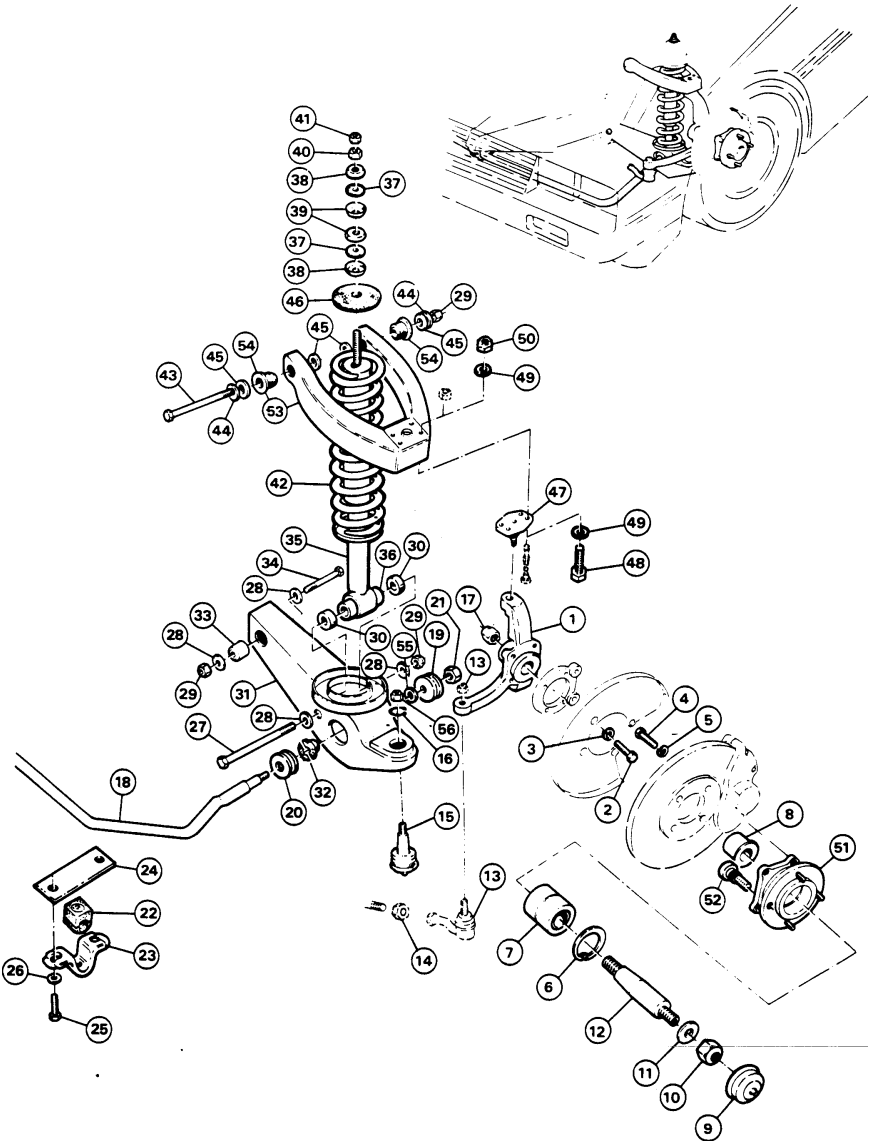

Before installing the hub/disk assembly, you should attach the front sway bar, since it is easier to get to this area before the disk is installed. Install the hub/disk assembly (with new bearings) last before installing the brake caliper. Ensure that all the suspension parts are torqued to specification (torque settings will appear in the next issue)

After I overhauled my suspension, my car took on a completely new feel. The steering is now very precise and the ride is stiff and sporty.



## Chapter 41 Events Calendar

### **'97 Kickoff Meeting & Dinner**

Date: Sat. Jan. 18, '97 6:00pm  
Stuart Anderson's Cattle Company  
3800 SW Cedar Hills Blvd.  
Beaverton

Please RSVP to Knut beforehand so that appropriate accommodations can be made.

### ***Upcoming events (to be finalized at '97 kickoff)***

Our club is in need of an events coordinator to help plan future events. If you are interested or have a suggestion for an event, please call me.

## DMC Heart Transplant

Below is a photo of the new engine I had installed in my DeLorean. The configuration as shipped includes everything except for the air cleaner. The A/C compressor and alternator were removed for shipping. As there are no more Motorola alternators to be had, the shipped engine is configured with the Ducellier alternator. I purchased the engine for about \$4000 through Specialty Automotive, and Foreign Car Specialists estimates installation could be done for about \$1500. If you are interested, call Chris at FCS (357-7049) for information.



## For Sale & Wanted

---

*Advertisement of  
DeLorean related items is  
provided to Chapter 41  
members free of charge.*

---

*For Sale: '81 (VIN 4514)  
DMC-12 w/ 41K miles.  
Manual/gray maintained  
by car collector. \$15000*

*Contact Tom H:631-8898*

---

*Wanted: Performance  
components for PRV6  
ground-up rebuild.*

*Contact Knut H:649-8053  
W:264-8419*

---

*Wanted: DeLorean with  
damaged or missing  
engine for project car.*

*Contact Knut H:649-8053  
W:264-8419*

---